

ver: 221216

Designed by Cassida Corporation, USA  
Assembled in China

©Copyright 2017 Cassida Corporation. All rights reserved.  
Specifications subject to change without notice. Cassida is a registered trademark of Cassida Corporation.

 Cassida<sup>®</sup>  
USA

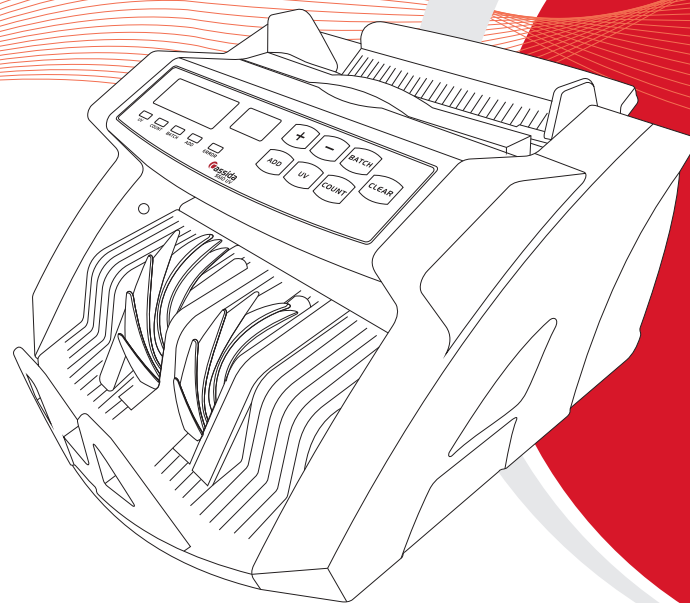

## USER MANUAL

Cassida 5510 Reliable Bill Counter For Retail

This manual contains important information on safety measures and operational features, please read it carefully before operating your currency counter and keep it for future reference.

## Table of contents

### 1. Introduction

1.1. About the Cassida 5510 .....	5
1.2. Box contents .....	5
1.3. Front and rear view .....	6
1.4. Control panel .....	9
1.5. Specifications .....	10
1.6. Important safety notes .....	10

### 2. Getting started

2.1. Powering up .....	11
2.2. Loading the hopper .....	11
2.3. Counting mode .....	12
2.4. Adding mode .....	12
2.5. Batching mode .....	12

### 3. Maintenance and Troubleshooting

3.1. Maintenance .....	12
3.2. Troubleshooting .....	14

### 4. Warranty and contact information

4.1 Warranty .....	15
4.2 Contacts .....	15

## 1. INTRODUCTION

### 1.1 About the Cassida 5510

Thank you for choosing the Cassida 5510 series currency counter. We hope you enjoy using it with reliable detection performance and user friendly operation.

Cassida's 5510 series currency counters are sophisticated yet simple to operate money processing machines.

Cassida 5510 series currency counter makes an invaluable aid in banks, retail stores, groceries, car washes, gas stations, bars, nightclubs, restaurants, movie theaters and any other cash intensive environment.

### 1.2 Box contents

- Cassida 5510 Currency Counter
- Power cord
- User manual
- External display
- Unit box

### 1.3 Front and rear views

Front view

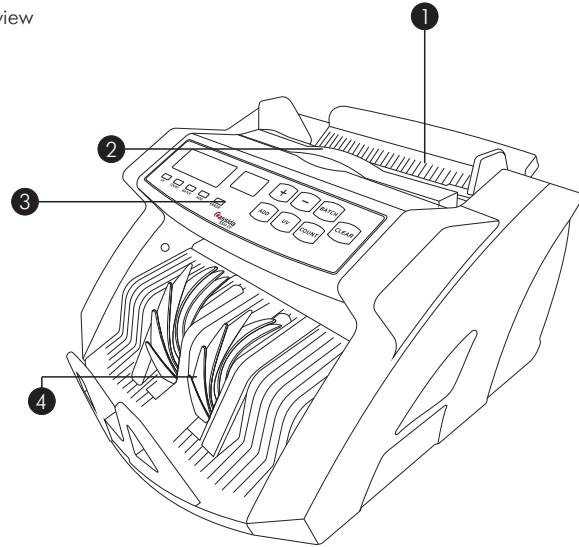

- 1. Hopper
- 2. Retractable handle
- 3. Control panel
- 4. Stacker

Rear view

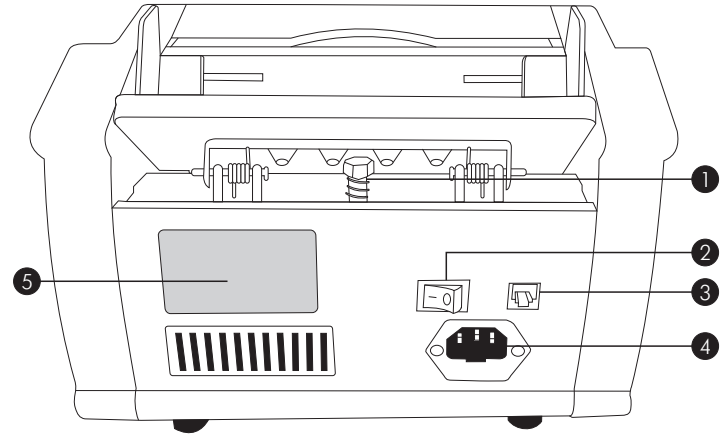

- 1. Feeding gap adjustment screw
- 2. Power switch
- 3. External display connection port
- 4. Power outlet & fuse
- 5. Backsticker

## Sensors location

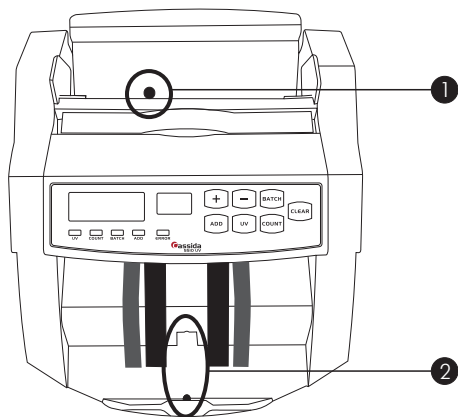

1. Hopper sensor
2. Stacker sensor

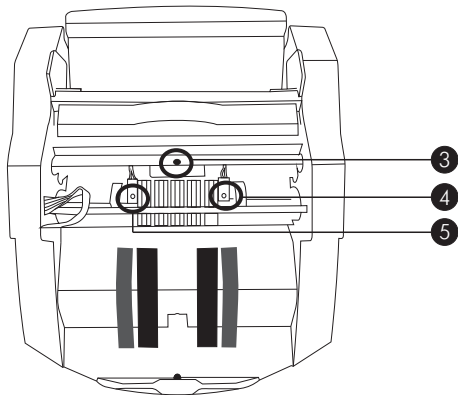

3. UV sensor
4. Counting sensor (left)
5. Counting sensor (right)

## 1.4 Control panel

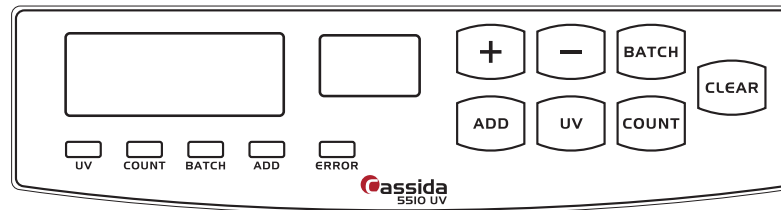

1. UV - Counterfeit detection activation key. When suspicious bill is detected display will inform user about the error.
2. BATCH - Batch mode activation key. Once the Batch is activated the corresponding indicator is on display. Default Batch number is set 100 pcs, to change the Batch number user can use + and - keys on control panel
3. ADD Activates add mode. Once the ADD is activated the corresponding indicator is on display.
4. Counting - activates simple counting mode (without detections). Once the Count is activated the corresponding indicator is on display.
5. Clear - Clear counting results
6. Error - Once the counting error appears indicator on error is on display

## Display

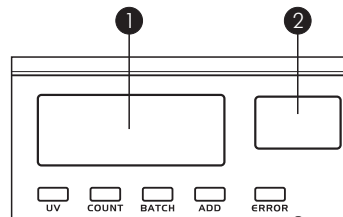

Display 1 - indicates number of counted notes

Display 2 - indicates Batch number

## 1.5 Specifications

Counting speed	1300 bills/min
Detections	UV, DD, SD (from 6 mm), HLF, CH
Hopper/stacker capacity	100/100 bills
Display	LED, red (4 digits for number of notes) and 3 (for batch number)
Power consumption	<80 Watts
Power source	220+/-10% V /50 Hz
Dimensions	295 x 240 x 175 mm
Weight	5 kgs

## 1.6 Important safety notes

When using this product, basic safety precautions should always be taken, including the following:

1. Do not use this product in areas where it may be exposed to water or any metal parts.
2. Unplug this product from the wall outlet before cleaning. Use a damp cloth and don't take it out with wet hands.
3. Put out the power cord taking it form the plug.
4. Only use the power cord supplied with the unit.
5. Carry out the unit only after powering it off.
6. If the unit was kept extended period of time in low temperatures, keep it in normal temperature conditions at least 2 hour prior powering on.

In order to use the unit without technical support of engineers please follow below rules:

1. Make sure the device is installed on a flat surface.
2. This product is designed for indoor use in a ventilated environment. Keep the unit away from direct sunlight and strong magnetic fields which could interfere with the counterfeit detection sensor.
3. Do not operate the unit in areas with high dust humidity. High dust level may prevent it proper operation.

## 2. GETTING STARTED

### 2.1 Powering up

Please make sure the hopper is empty and turn the power switch on. The unit will conduct a self-check by spinning the counting wheels several times. The screen will display "0" when the unit is ready.

### 2.2 Loading the hopper

Loading the hopper correctly is important in order to avoid jams and speed up the operation of the counter.

Proper hopper loading is shown in the following diagrams.

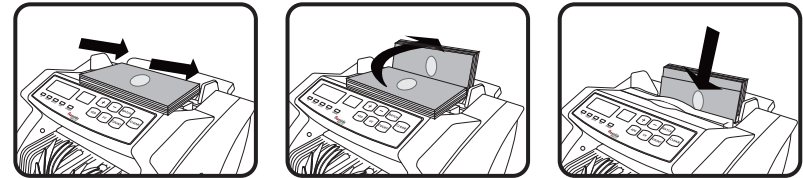

Adjust the gap with feeding gap adjustment screw based on thickness and condition of bills.

### 2.3 Counting mode

After the machine is turned on, it defaults to counting mode.

To count bills, place them in the hopper (follow the procedure described in 2.2 Loading the hopper).

The machine will start counting automatically and will move the bills from the hopper to the stacker as it counts them. The machine will stop counting when the hopper is completely emptied and will emit a confirmation beep. The counted number of the bills will be displayed.

### 2.4. Adding Mode

To switch to adding mode, press the ADD button until the ADD indicator is on. Place the bills in the hopper and start count.

The unit will continue counting after adding new batch, and the next counting result will be added to previous.

### 2.5. Batching mode

To switch to adding mode, press the BAT button until the BAT indicator is on. Default batch number is 100 pcs of bills. To change the batch number press "+" or "-" on the control panel.

## 3. MAINTENANCE AND TROUBLESHOOTING

### 3.1. Maintenance

Taking regular care of your currency counter will allow you to avoid 80% of the problems arising during operation.



**You should always turn the machine off and disconnect the power cord before cleaning the unit.**

- Most operational problems can be avoided by regular care and preventative maintenance. Taking regular care of your currency counter will significantly increase its lifetime and help you avoid costly repairs.

To avoid problems:

- Make sure there are no metal clips or rubber bands in the bills you are going to count;
- Be sure to follow the proper procedure for loading the hopper, refer to part "2.2 Loading the hopper";
- To get the best results out of your counter the following maintenance is recommended on a daily basis:  
Use a Cassida air duster and a soft bristle brush to remove any dust or debris from the interior of the machine.
- When not using your counter for an extended period of time, cover it with a drop cloth or plastic sheeting to prevent dust from settling inside.
- Complete maintenance service is recommended once every 3 months.

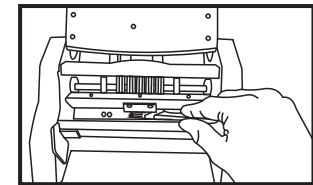
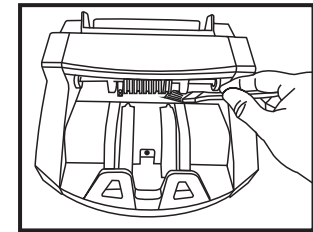
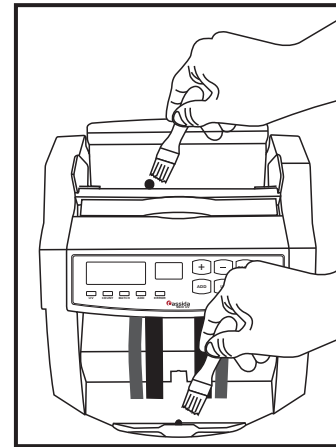

### 3.2 Troubleshooting

Error Code	Description	Solution
E01	Left counting sensor has collected dust or broken	1) Clean the left sensor from dust 2) Replace left counting sensor
E02	Right counting sensor has collected dust or broken	1) Clean the left sensor with a soft bristle brush 2) Replace left counting sensor
E03	Encoding sensor error	Contact the service center
E04	Hopper sensor has collected dust or broken	1) Clean the hopper sensor from dust 2) Replace the hopper sensor
E05	Stacker sensor has collected dust or broken	1) Clean the stacker sensor from dust 2) Replace the stacker sensor
E10	1. The unit is under direct sun light 2. UV sensitivity is too high	1) Put the unit away from direct sun light 2) Adjust UV sensitivity level (Contact the service center).
E11	Control panel cord is not connected well	Connect control panel cord properly
EE1	Suspicious bill detected by UV	Remove suspicious bill, press Clear to erase the error and press Clear again to continue counting.
EE4	1) Half bill detected 2) Left/right counting sensor is broken	1) Remove suspicious bill, press Clear to erase the error and press Clear again to continue counting. 2) Replace left/right counting sensors
EE5	Double bill detected	Check gap adjustments using adjustment screw

## 4. WARRANTY AND CONTACT INFORMATION

### 4.1 Warranty

Warranty is effective for a period of one year from the date of purchase. In most cases, the malfunction of the machine can be resolved by cleaning the unit.

- Customer should allow Cassida the time and opportunity to test and diagnose the machine to determine warranty and non-warranty claims.
- After receiving and unpacking the units, Customer shall keep the package and its user manual. Warranties are canceled in the event the device is transported in a non-original packaging or operation/maintenance conditions are not met.
- Company is not responsible for unit malfunction due to improper maintenance, storage and transportation including mechanical damage.
- Manufacturer is entitled to introduce updated software, not described in the current user manual.

#### Non-warranty service:

Cassida can perform maintenance and cleaning for an extra fee. For a non-warranty repair or maintenance quotation, contact Cassida Technical Support.

Warranty service is not available in the following cases:

- Cleaning of the unit from dust and mud
- Absence of a warranty card or an incorrectly filed warranty card
- Operation or maintenance rules requirements set in the user manual are not met
- There is mechanical damage to the unit or the seal portions of the unit have been opened or tampered with
- There are foreign objects or liquid inside of the unit.

#### Shipping:

The warranty does not cover shipping cost to or from Cassida's Technical Service Center. Before shipping the unit to the Cassida's Technical Service Center the warranty card must be filled out with model full name and number, serial number, cause for service, errors occurred.



## 4.2 Contacts

### Technical Support contact information:

e-mail: [fabin.johny@cassida.me](mailto:fabin.johny@cassida.me)

tel: 042 739 328

[www.cassida.me](http://www.cassida.me), [www.cassidausa.com](http://www.cassidausa.com)

When contacting Cassida Technical Support, please have the following:

- Product model – Located on the back side of your currency counter
- Serial number – Located on the back side of your currency counter
- Nature of the problem – What happens, and when did it happen? Did the machine display an error message?
- Steps already taken to resolve the problem, and the results.

Office # 101,

Biyat Complex (Landmarks: Emirates Billiard Centre)

Hor Al Anz East, Behind Al Mamzar Centre

Dubai - United Arab Emirates

PO box 454867